

TITLE**10G SFP+ ER Transceiver (1550nm)****1. SCOPE**

ZFTCERC1550A1ST SFP+ transceivers, according to Enhanced 8.5 and 11.3 Gigabit Small Form Factor Pluggable “SFP+” Multi-Sourcing Agreement (MSA) SFF-8431 and SFF-8472, revision 10.4, are designed for 10G Ethernet serial optical data communication up to 80km on single mode fiber. They are compliant with IEEE Std 802.3-2005 10Gb Ethernet 10GBase-ER/EW.

2. PRODUCT DESCRIPTION**2.1 PRODUCT NAME AND SERIES NUMBER(S)****10G ER SFP+ Transceiver**

Part Number	Data Rate	Wavelength (nm)	Distance	Media	Power (dBm)	Sen. (dBm)	Connector	Tem.
ZFTCERC1550A1ST	10G	1550	40km	SMF	-8 ~ 0.5	-14.4	LC	C

TITLE
10G SFP+ ER Transceiver (1550nm)

2.2 DIMENSIONS, MATERIALS, PLATINGS AND MARKING

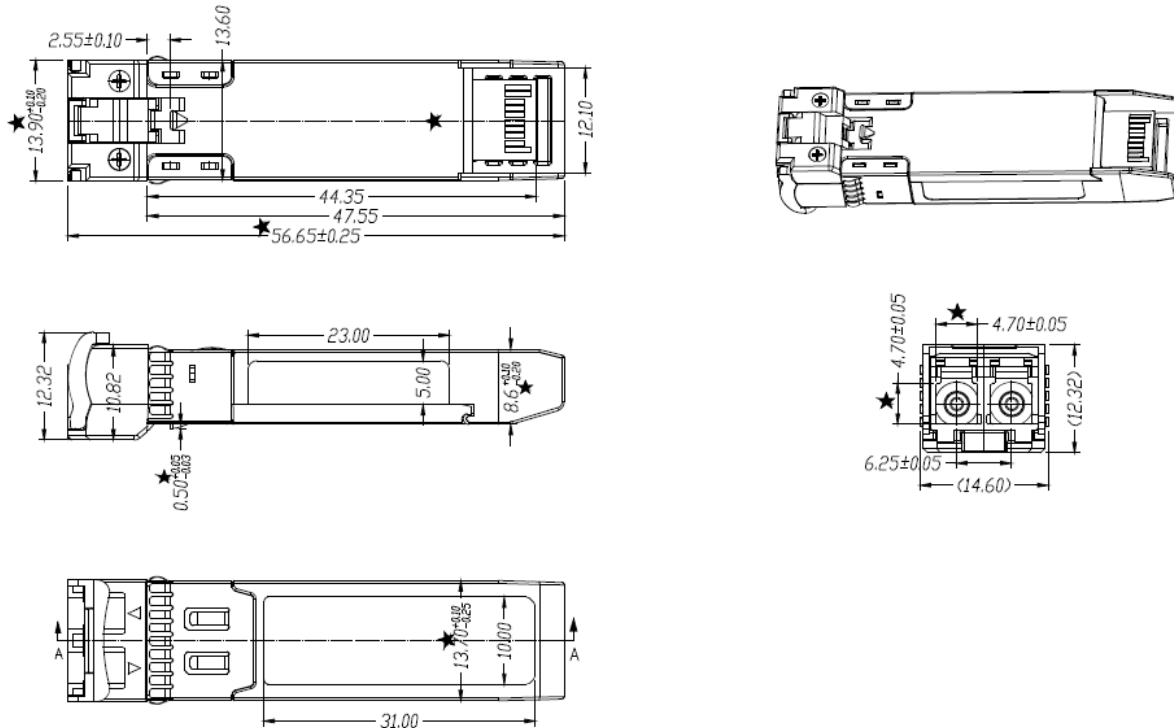

Unit is millimeter. All dimensions are ±0.1mm unless otherwise specified.

3. APPLICABLE DOCUMENTS AND SPECIFICATIONS

- Compliant with SFP+ MSA
- 10G Ethernet 10GBASE-ER/EW
- Management interface specifications per SFF-8431 and SFF-8472
- Cooled 1550nm EML Laser
- Class 1 laser safety certified

4. QUALIFICATION

- Electrostatic Discharge (ESD) to the Electrical Pins
- Electrostatic Discharge (ESD) to the LC Connector
- RoHS compliance

TITLE
10G SFP+ ER Transceiver (1550nm)

5. Absolute Maximum Ratings & Recommended Operating Conditions

Absolute Maximum Ratings				
Parameter	Symbol	Min.	Max.	Unit
Storage Temperature	TS	-40	+85	°C
Supply Voltage	VCC3	-0.5	4	V
Relative Humidity(Non-condensing)	RH	0	85	%

Recommended Operating Conditions					
Parameter	Symbol	Min.	Typical	Max.	Unit
Operating Case Temperature	TC	0	25	70	°C
Operating Case Temperature	TI	-40		85	°C
Power Supply Voltage	VCC3	3.135	3.3	3.465	V
Power Dissipation	Pd		1.5		W
Data Rate				11.3	Gbps
Transmission Distance				40	Km

Transmitter Operating Characteristic-Optical, Electrical						
Parameter	Symbol	Min.	Typical	Max.	Unit	Note
Center Wavelength	λ_c	1530	1550	1565	nm	
SMSR	SMSR	30			dB	
Launch Optical Power	Po	-2	-	+2	dBm	
Extinction Ratio	ER	8.2			dB	
Pout @TX-Disable Asserted	Poff			-30	dBm	
Transmitter and Dispersion Penalty	TDP	-	-	3.0	dB	-
Optical Return Loss Tolerance	ORLT	21	-	-	dB	-
Pout @TX-Disable Asserted	Poff	-	-	-30	dBm	1
Relative Intensity Noise	RIN12OMA	-	-	-128	dB/Hz	
Input differential impedance			100		Ω	
Differential data input swing		100		700	mV	

TITLE
10G SFP+ ER Transceiver (1550nm)

Tx_Fault	High	2.0		VCCHOST		V	Tx_Fault,
	Low	0		0.8		V	
Tx Disable	VIH	2.0		VCCHOST		V	Tx Disable
	VIL	0		0.8		V	

Receiver Operating Characteristic-Optical, Electrical							
Parameter	Symbol	Min.	Typ.	Max.	Unit	Note	
Center Wavelength	λ_r	1530	-	1565	nm		
Receiver Sensitivity (Pavg)	S			-15.5	dBm		
Receiver Overload (Pavg)		-1			dBm		
LOS Assert	LOS_A	-30		-	dBm		
LOS Dessert	LOS_D			-17	dBm		
LOS Hysteresis		0.5		-	dB		
Receiver reflectance				26	dB		
Differential data output swing		300	-	850	mV		

TITLE
10G SFP+ ER Transceiver (1550nm)

6. Applications Note :

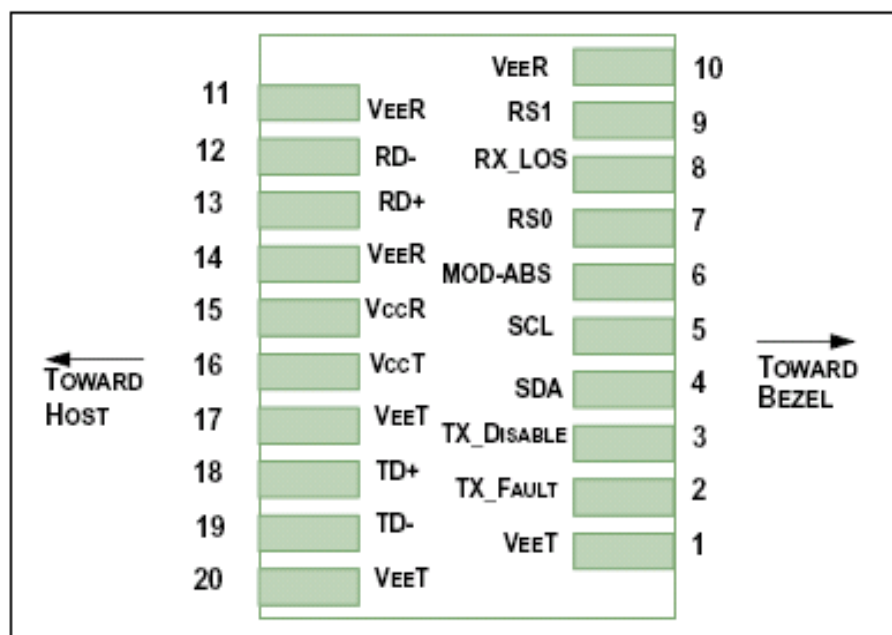

Pin Definitions

Pin Assignment

Pin	Logic	Symbol	Name/Description	Note
1		VeeT	Module Transmitter Ground	Note1
2	LVTTTL-O	TX_Fault	Module Transmitter Fault	Note2
3	LVTTTL-I	TX_Disable	Transmitter Disable; Turns off transmitter laser output	Note3
4	LVTTTL-I/O	SDA	2-wire Serial Interface Data Line (Same as MOD-DEF2 as defined in the INF-8074i)	Note4
5	LVTTTL-I/O	SCL	2-wire Serial Interface Clock (Same as MOD-DEF1 as defined in the INF-8074i)	Note4
6		MOD_ABS	Module Absent, connected to VeeT or VeeR in the module	Note5
7	LVTTTL-I	RS0	Rate Select 0, optionally controls SFP+ module receiver.	
8	LVTTTL-O	RX_LOS	Receiver Loss of Signal Indication (In FC designated as RX_LOS, in SONET designated as LOS, and in Ethernet designated at Signal Detect)	Note2
9	LVTTTL-I	RS1	Rate Select 1, optionally controls SFP+ module transmitter	
10		VeeR	Module Receiver Ground	Note1
11		VeeR	Module Receiver Ground	Note1
12	CML-O	RD-	Receiver Inverted Data Output	
13	CML-O	RD+	Receiver Non-Inverted Data Output	
14		VeeR	Module Receiver Ground	Note1

TITLE

10G SFP+ ER Transceiver (1550nm)

15		VccR	Module Receiver 3.3 V Supply	
16		VccT	Module Transmitter 3.3 V Supply	
17		VeeT	Module Transmitter Ground	Note1
18	CML-I	TD+	Transmitter Non-Inverted Data Input	
19	CML-I	TD-	Transmitter Inverted Data Input	
20		VeeT	Module Transmitter Ground	Note1

Notes:

- [1] The module signal ground pins, VeeR and VeeT, shall be isolated from the module case.
- [2] This pin is an open collector/drain output pin and shall be pulled up with 4.7k-10kohms to Host_Vcc on the host board. Pull ups can be connected to multiple power supplies, however the host board design shall ensure that no module pin has voltage exceeding module VccT/R + 0.5 V.
- [3] This pin is an open collector/drain input pin and shall be pulled up with 4.7k-10kohms to VccT in the module.
- [4] See sff-8431 4.2 2-wire Electrical Specifications .
- [5] This pin shall be pulled up with 4.7k-10kohms to Host_Vcc on the host board.

Recommended Application Interface Block Diagram

